

DNA

Based on and adapted from the Genetic Science Learning Center's "How to Extract DNA from Any Living Thing" (<http://learn.genetics.utah.edu/units/activities/extraction/>) and BioRad's "Genes in a bottle" (http://www.bio-rad.com/cmc_upload/Literature/54133/4110034B.pdf), by Jennifer Doherty and Dr. Ingrid Waldron, Department of Biology, University of Pennsylvania, © 2007¹

Today you will extract DNA from some of your cells and learn more about DNA.

Why is DNA so important in biology? What is the function of DNA?

Where is DNA found in our bodies?

Draw a simple diagram of a cell, showing the cell membrane and the DNA in chromosomes surrounded by a nuclear membrane.

Extracting DNA from Your Cells

Cells from the lining of your mouth come loose easily, so you will be able to collect cells containing your DNA by swishing a liquid around in your mouth.

The cells from the lining of your mouth also come off whenever you chew food. How do you think your body replaces the cells that come off the lining of your mouth when you eat?

To extract DNA from your cells, you will need to separate the DNA from the other types of biological molecules in your cells. What are the other main types of large biological molecules in cells?

You will be using the same basic steps that biologists use when they extract DNA (e.g. to clone DNA or to make a DNA fingerprint). You will follow these 3 easy steps to extract the DNA:

- D**etergent
- e**nzymes (meat tenderizer)
- A**lcohol

Getting Your Sample of Cells

Obtain a cup with sports drink. You will need to get thousands of your cheek cells in the sports drink in order to extract enough DNA to see. Therefore you should swish the sports drink around in your mouth vigorously for at least one minute. Then spit the drink back into the cup.

Step 1: Detergent

Add a small amount of detergent to a test tube (about 0.25 mL). Put a glove on the hand you will use to hold your test tube, not the hand you will use to pour. Now carefully pour the drink containing your cheek cells into the test tube with detergent until the tube is **half full**.

Why am I adding detergent?

To get the DNA out of your cheek cells you need to break open both the cell membranes and the nuclear membranes. Cell membranes and nuclear membranes consist primarily of lipids.

¹ Teachers are encouraged to copy this student handout for classroom use. A Word file (which can be used to prepare a modified version if desired), Teacher Preparation Notes, comments, and the complete list of our hands-on activities are available at http://serendip.brynmawr.edu/sci_edu/waldron/.

Dishwashing detergent, like all soaps, breaks up lipids. This is why you use detergents to remove fats (which are lipids) from dirty dishes. Adding the detergent to your cheek cell solution will break open the cell membranes and nuclear membranes and release your DNA into the solution.

Step 2: Enzymes

Add a pinch of enzyme (meat tenderizer) to your test tube. With your gloved thumb (or palm) covering the top of the test tube; gently invert the tube five times to mix. Let the mixture sit for at least 10 minutes. While you are waiting, you will learn about the structure of DNA. Remove your glove and throw it in the garbage.

Why am I adding enzymes?

The nucleus of each of your cells contains multiple long strands of DNA with all the instructions to make your entire body. If you stretched out the DNA found in one of your cells, it would be 2-3 meters long. To fit all of this DNA inside a tiny cell nucleus, the DNA is wrapped tightly around proteins. The enzyme in meat tenderizer is a protease, which is an enzyme that cuts proteins into small pieces. As this enzyme cuts up the proteins, the DNA will unwind and separate from the proteins.

The protease in meat tenderizer actually comes from plants, but animals also make proteases. Where in your body do you think you make protein-cutting enzymes?

DNA Structure

As you can see in the figure below, DNA consists of two strands of **nucleotides** wound together in a spiral called a **double helix**. Each nucleotide contains a phosphate and a sugar molecule called a **deoxyribose** (which explains why the complete name for DNA is deoxyribonucleic acid). Each nucleotide also has one of four different nitrogenous bases: **adenine (A)**, **thymine (T)**, **guanine (G)**, and **cytosine (C)**.

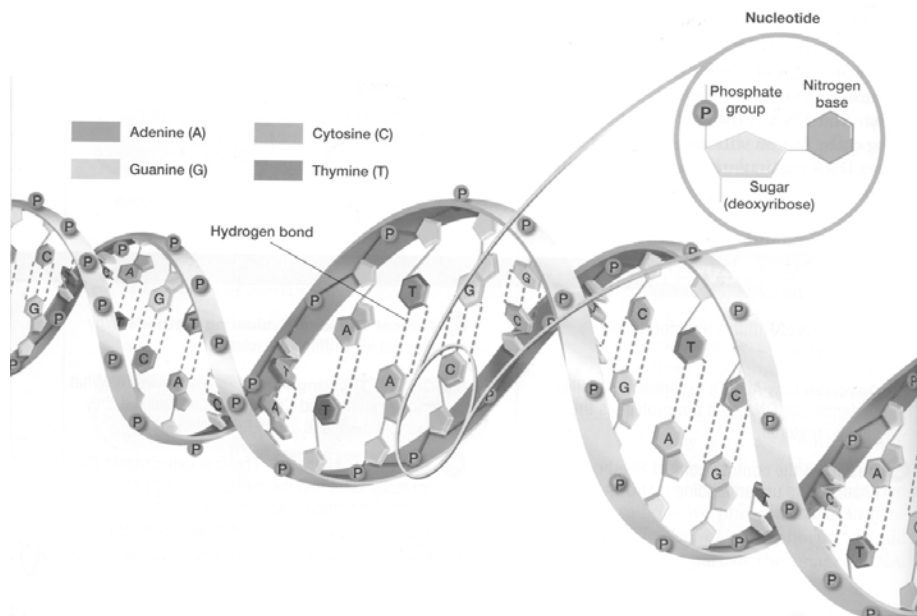

(Adapted from Figure 9.4 in Biology by Johnson and Raven)

The drawings below show a very small section of the DNA double helix from three very different organisms: a plant, a mammal, and a bacterium. Each strand of DNA shown contains five nucleotides, each with a:

S = five carbon sugar molecule called deoxyribose

P = phosphate group

A = adenine, **C** = cytosine, **G** = guanine, **T** = thymine, the DNA nucleotide bases

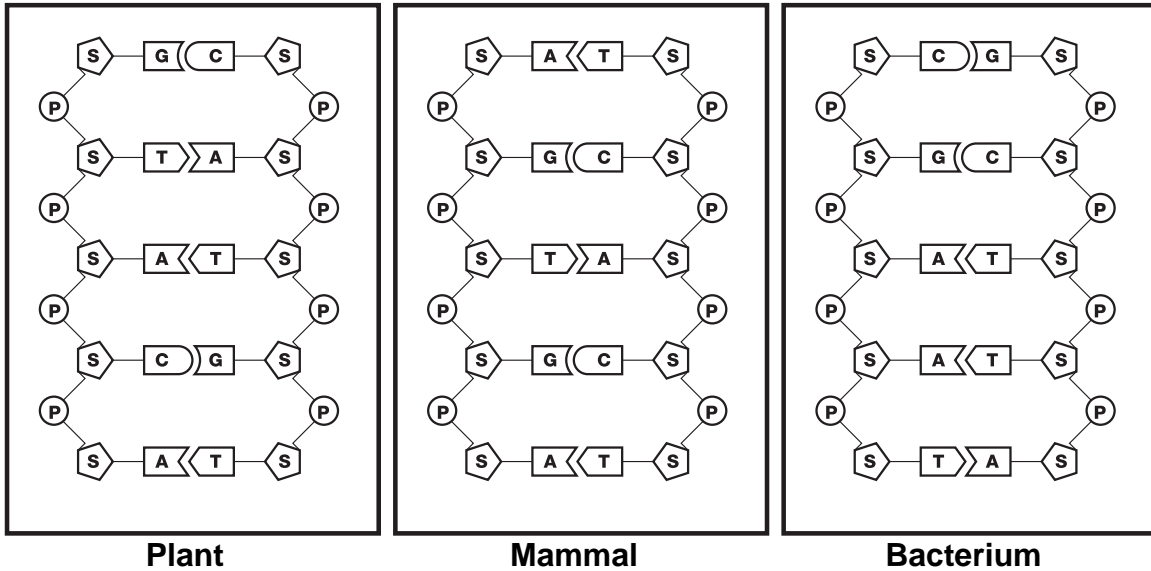

(From BioRad's "Forensic DNA fingerprinting kit" http://www.bio-rad.com/cmuc_upload/Literature/12525/4006096G.pdf)

You can see that the phosphate from one nucleotide is bonded to the sugar in the next nucleotide to form the backbone of each strand in the DNA molecule. The bases of the nucleotides in each strand of DNA extend toward each other in the center of the DNA double helix molecule. A crucial aspect of DNA structure is the **base-pairing rule**: **A** in one strand always pairs with **T** in the other strand, and **G** in one strand always pairs with **C** in the other strand. You will see later that this base-pairing is crucial for the cell to make new copies of each DNA molecule in preparation for cell division.

1. Compare the sugar-phosphate arrangement in the backbone of the DNA from the plant, the mammal and the bacterium. Are there any differences?
2. Which bases are present in the DNA of the plant? The mammal? The bacterium?
Are the same bases present in all three cases?
Are the bases in the same order?
3. Describe the pattern of base pair matching for the two strands in the plant's DNA. In other words, which types of bases are paired together? Does the DNA from the mammal follow the same base-pairing rule as the DNA from the plant? Is base-pairing the same or different in the DNA of the bacterium?

Which characteristics are similar in the DNA of plants, mammals and bacteria? What is the only characteristic that differs between these segments of DNA from a plant, a mammal and a bacterium? These observations illustrate the similarity of the basic structure of DNA in all living organisms. The genetic differences between plants, mammals and bacteria are due to differences in the sequence of bases in their DNA.

Step 3: Alcohol

Using a pipette, slowly add cold rubbing alcohol into the test tube; let the alcohol run down the side of the test tube so it forms a layer on top of the soapy liquid. Add alcohol until you have about 2 cm of alcohol in the tube. Alcohol is less dense than water, so it floats on top. **Do not mix or bump the test tube for 10 minutes.** DNA molecules will clump together where the soapy water below meets the cold alcohol above, and you will be able to see these clumps of DNA as white strands. While you are waiting for the DNA to become visible you will learn about DNA replication.

Why am I adding alcohol? The cold alcohol reduces the solubility of DNA. When cold alcohol is poured on top of the solution, the DNA precipitates out into the alcohol layer, while the lipids and proteins stay in the solution.

DNA Replication

Cells in our body are dividing all the time. For example, cell division in the lining of your mouth provides the replacements for the cells that come off whenever you chew food. Before a cell can divide, the cell must make a copy of all the DNA in each chromosome; this process is called **DNA replication**. Why is DNA replication necessary before each cell division?

As shown in the figure below, the first step in DNA replication is the separation of the two strands of the DNA **double helix** by the enzyme **DNA helicase**. After the two strands are separated, another enzyme, **DNA polymerase**, forms a new matching DNA strand for each of the old DNA strands. DNA polymerase forms the new matching DNA strand by adding nucleotides one at a time and joining each new nucleotide to the previous nucleotide in the growing DNA strand. Each nucleotide added to the new strand of DNA follows the base-pairing rule with the matching nucleotide on the old strand of DNA. The result is two identical DNA double helices.

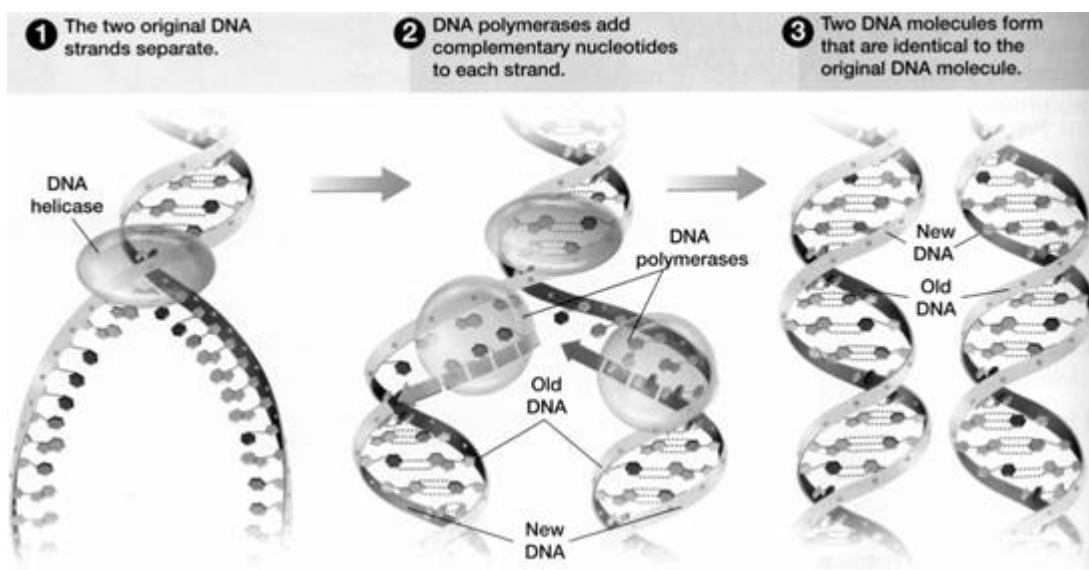

(Adapted from Figure 9.9 in *Biology* by Johnson and Raven)

In the drawing below, the small segment of plant DNA (from page 3) is shown after the two strands of the DNA molecule have been separated by DNA helicase. Your job is to play the role of DNA polymerase and create the new matching strands of DNA to make two pieces of double-stranded DNA in the drawing below. Use the base-pairing rule to determine which nucleotides to add.

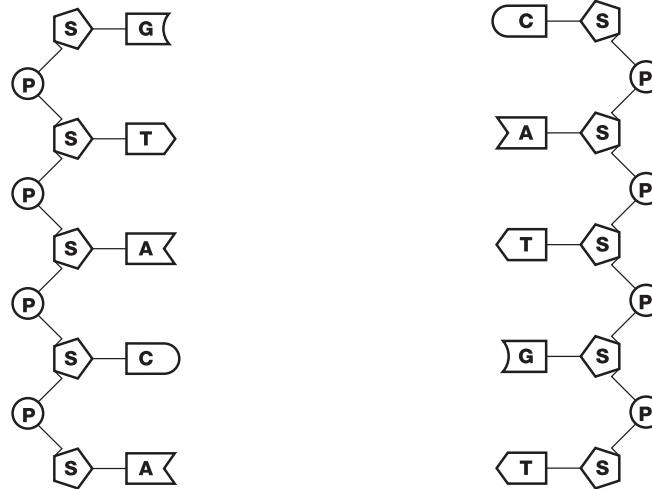

Now look at both of the double-stranded pieces of DNA you have created. Are there any differences between the two strands? Are these new double-stranded pieces of DNA the same as or different than the original piece of plant DNA (shown on page 3)?

During actual DNA replication sometimes mistakes are made and the wrong nucleotide is added to the new strand of DNA. DNA polymerase can “proofread” each new double helix DNA strand for mistakes and backtrack to fix any mistakes it finds. To fix a mistake it finds, DNA polymerase removes the incorrectly paired nucleotide and replaces it with the correct one. If a mistake is made and not found, the mistake can become permanent. Then, any daughter cells will have this same change in the DNA molecule. These changes are called **point mutations** because they change the genetic code at one point, i.e. one nucleotide. Point mutations can result in significant effects, such as the genetic disease, sickle cell anemia.

Making Your Necklace

By now your DNA should be visible as clumps of white strands floating in the alcohol layer. There may be air bubbles attached to the strands.

Use a pipette to suck up your DNA from the test tube and transfer it to the small capped tube. Be careful to squeeze the air out of the pipette before you put the pipette in the test tube; then gently suck up your DNA. Fill the small capped tube the rest of the way with alcohol. Close the cap of the tube around a piece of string. Now you have a necklace with your very own DNA!

Questions

- Which of the following do you think will contain DNA? Explain your reasoning.
bananas ___ concrete ___ fossils ___ meat ___ metal ___ spinach ___ strawberries ___
- Describe the function of DNA polymerase. Explain why each part of the name DNA polymerase (DNA, polymer, -ase) makes sense.

Bonus Question: Suppose that DNA did not have a double helix structure, and instead DNA was single-stranded. Imagine that a cell with this single-stranded DNA was ready to begin cell division. How could a cell replicate single-stranded DNA so the daughter cells could receive an exact copy of the genes present in the original cell? Use your answer to explain why it is an advantage for DNA to have a double helix structure with paired nucleotides.